



ICM-MP1501

Mercury Controller

Installation and specifications

1. Overview

1.1 MP1501(ICM-MP1501) controller with paired interface for one physical barrier

The MP1501 intelligent controller provides decision making, event reporting, and database storage for the downstream for the Mercury hardware platform. Two reader interfaces configured as paired, or alternate readers provide control for one physical barrier.

Host communication is via the on-board 10-BaseT/100Base-TX Ethernet port.

Reader port 1 (TB1301) can accommodate a reader that uses TTL (D1/D0, Clock/Data), F/2F, or 2-wire RS-485 device signaling (for example an OSDP reader). Reader port 1 also provides tri-state LED control and buzzer control (one wire LED mode only). This port can also use multiple 2-wire RS-485 multi-dropped devices, such as up to two OSDP readers, or up to eight remote serial I/O devices.

Reader port 2 (TB1300 and TB300) can accommodate a reader that uses TTL (D1/D0, Clock/Data), or F/2F signaling. Reader port 2 also provides tri-state LED control, and buzzer control (one wire LED mode only). Two Form-C contact relay outputs can be used for door strike control or alarm signaling. The relay contacts are rated at 2 A @ 30 V DC resistive, dry contact configuration. Two inputs are provided that can be used for monitoring the door contact, exit push button, or alarm contact. Input circuits can be configured as unsupervised or supervised.

The MP1501 (ICM-MP1501) requires Power over Ethernet (PoE or PoE+) or 12 V DC for power. For PoE, UL compatibility was verified and tested with Pihong, Model POE29U-1AT (Primary Rated: 100-240 V AC, 0.8 A, 50/60 Hz; Secondary rated: 56 V DC, 0.536 A, 30 W). The MP1501 can be mounted in a 3-gang switch box; a mounting plate is supplied with the unit, or the MP1501 can be mounted in an enclosure; the supplied mounting plate has mounting holes that match the MR50 mounting footprint.

1.2 MP1501 (ICM-MP1501) hardware

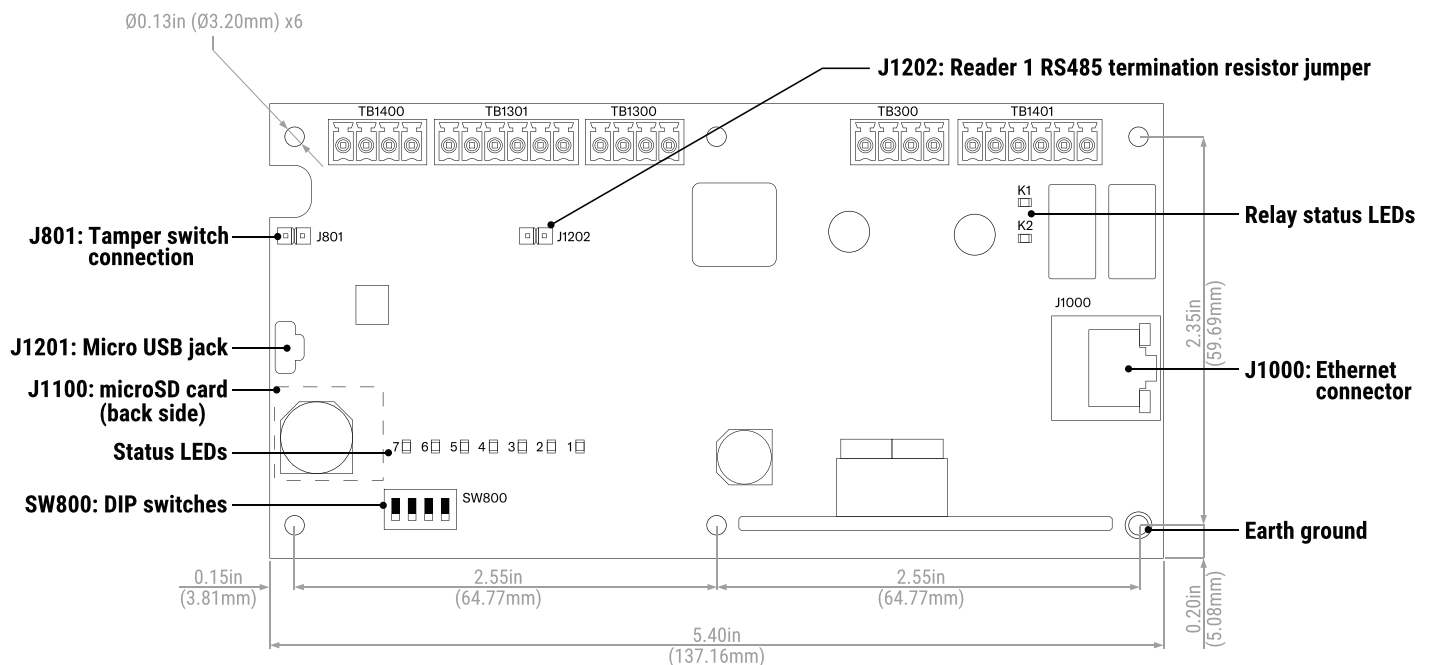

2. Wiring and setup

2.1 MP1501 (ICM-MP1501) connections

TB1400-1	IN1	Input 1 - Inputs used for Access Control only, not Burglar Alarm inputs
TB1400-2	IN1	
TB1400-3	IN2	Input 2 - Inputs used for Access Control only, not Burglar Alarm inputs
TB1400-4	IN2	

TB1301-1	VO	Reader 1 power output – 12 V DC
TB1301-2	LED	Reader 1 LED output
TB1301-3	BZR	Reader 1 buzzer output
TB1301-4	CLK	Reader 1 CLK/Data 1/TR+ (A) ¹
TB1301-5	DAT	Reader 1 DAT/Data 0/TR- (B) ¹
TB1301-6	GND	Reader 1 ground

TB1300-1	LED	Reader 2 LED output
TB1300-2	BZR	Reader 2 buzzer output
TB1300-3	CLK	Reader 2 CLK/Data 1 input
TB1300-4	DAT	Reader 2 DAT/Data 0 input

TB300-1	VO	Auxiliary power output – 12 V DC
TB300-2	GND	Auxiliary power output ground
TB300-3	VIN	Input power – 12 V DC (from local power supply)
TB300-4	GND	Input power ground

TB1401-1	NO	Relay K1 – Normally open contact
TB1401-2	1-C	Relay K1 – Common contact
TB1401-3	NC	Relay K1 – Normally closed contact
TB1401-4	NO	Relay K2 – Normally open contact
TB1401-5	2-C	Relay K2 – Common contact
TB1401-6	NC	Relay K2 – Normally closed contact

1. Terms (A) and (B) are from the RS-485 standard.

2.2 Jumpers

Jumpers	Set at	Description
J1201	N/A	Micro USB port (2.0)
J1000	N/A	10-Base-T/100Base-TX Ethernet connection
J801		Cabinet tamper switch input: short = tamper secure
J1100	N/A	microSD card
J1202	Open	Reader 1 RS485 termination jumper. Fit jumper to enable termination resistor.

2.2.1 J1202 OSDP termination jumper

The J1202 jumper is located next to the reader port and controls OSDP termination. This jumper should be closed when an OSDP reader is used. When using a non-OSDP reader the jumper should be open.

Important: Failure to properly set the OSDP termination jumper could cause reader communication issues.

2.3 DIP switches

The four switches on the S1 DIP switch configure the operating mode of the MPI501 processor. DIP switches are read on power-up except where noted.

1	2	3	4	Definitions
OFF	OFF	OFF	OFF	Normal operating mode.
ON	X	X	X	After initialization, enable default User Name (admin) and Password (password). The switch is read on the fly, a re-boot is not required. See IT security for additional information.
OFF	ON	X	OFF	Use factory default communication parameters.
ON	ON	X	OFF	Use OEM default communication parameters. Contact system manufacturer for details. See Bulk erase configuration memory .
ON	ON	OFF	OFF	Bulk erase prompt mode at power up. See Bulk erase configuration memory .
X	X	X	ON	Makes the MPI501 (ICM-MPI501) report and function like an LP1501. To be used in situations where the host software has not been updated to support the MP series product line.

Note:

- All other switch settings are unassigned and reserved for future use.
- X = It doesn't matter if the switch is on or off.

2.4 Factory default communication parameters

Interface 1 (NIC1)

Network: static IP address	192.168.0.251
Subnet mask	255.255.0.0
Default gateway	192.168.0.1
DNS server	192.168.0.1
Primary host port	IP server, Data security: TLS if Available, port 3001, communication address: 0
Alternate host port	Disabled

2.5 Bulk erase configuration memory

The bulk erase function can be used for the following:

- Erase all configuration and cardholder database (sanitize board, less third party applications).
- Update OEM default parameters after OEM code has been changed.
- Recover from database corruption causing the MPI501 board to continuously reboot.

Note: If clearing the memory does not correct the initialization problem, contact Tech Support (support@idcubesystems.com).

2.5.1 Bulk erase steps

1. Set SW800 DIP switches 1 and 2 to **ON**, and 3 and 4 to **OFF**.
2. Apply power to the MPI501 board. LED 1 will flash during panel boot up.
3. After bootup is complete, LEDs 1 and 2, and LEDs 3 and 4 start flashing back and forth alternately at a rate of 0.5 seconds. Within 10 seconds of this beginning, change DIP switch 1 to **OFF**.
4. When complete, only LEDs 1 and 4 will flash for about three seconds.
5. The MPI501 board will restart the boot process and be available at the default IP address of 192.168.0.251.



Caution: Do not remove power during the bulk erase process.

2.6 Input power

The MPI501 (ICM-MPI501) is powered by one of the following two ways:

- Power is supplied via the Ethernet connection using PoE or PoE+
- Local 12 V DC power supply, TB300-3 (VIN), TB300-4 (GND)

2.7 Reader/serial I/O device wiring

Reader port 1 supports TTL (D1/D0, Clock/Data), F/2F, or 2-wire RS-485 device(s). Reader port 2 supports TTL (D1/D0, Clock/Data), or F/2F. Power to reader port 1 is 12 V DC at 600 mA maximum per port. The reader connected to reader port 2 may be powered from the 12 V DC auxiliary power supply output; TB1301-1 and TB1301-2. Readers that require different voltage or have high current requirements should be powered separately. Refer to the reader manufacture specifications for cabling requirements. In the 2-wire LED mode the buzzer output is used to drive the second LED. Reader port configuration is set via the host software.

Reader port 1 can support up to eight 2-wire RS-485 remote serial I/O devices using MSP1 protocol, or up to two OSDP devices. If two OSDP devices are used, reader port 2 will not support a third reader. If only one OSDP device is configured, then reader port 2 is available for a second reader. The maximum cable length is 2000 feet. (610 m). Do not terminate any RS-485 devices connected to reader port 1.

Note: Data 0 and Data 1 wires for Wiegand may be reused for OSDP. However, standard Wiegand cable may not meet RS-485 twisted pair recommendations. The reuse of cable works best on shorter cable lengths at lower data rates.

Important: Failure to correctly set the OSDP termination jumper settings can cause communication issues.



Caution: When powering remote device(s) from the MP1501 (ICM-MP1501), do not exceed the maximum current limit. Cable gauge must also be evaluated. See **Specifications** for details.

2.7.1 Reader wiring diagrams

Reader port 1, typical reader 1
(OSDP installation)

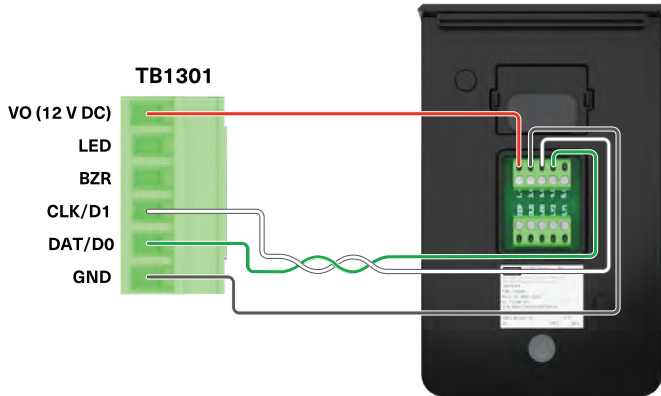

Reader port 1, typical reader 1
(Wiegand or Clock/Data installation)

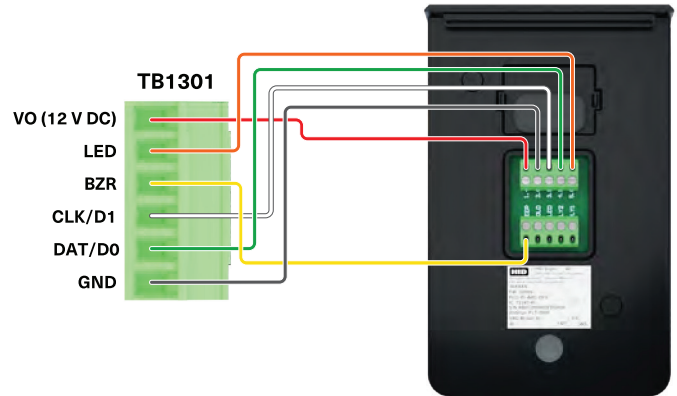

Reader port 2, typical reader 1
(Wiegand or Clock/Data installation)

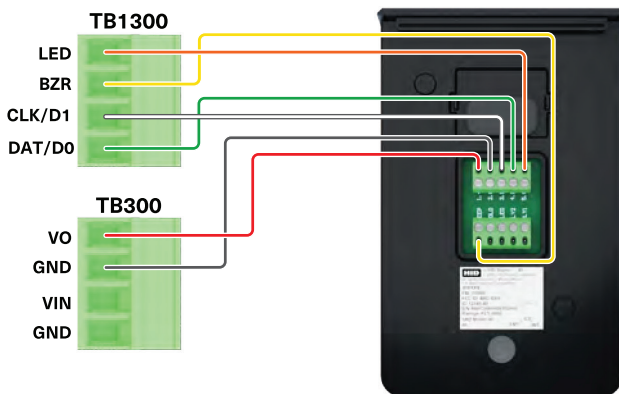

Reader port 1, typical reader 1
(OSDP installation)

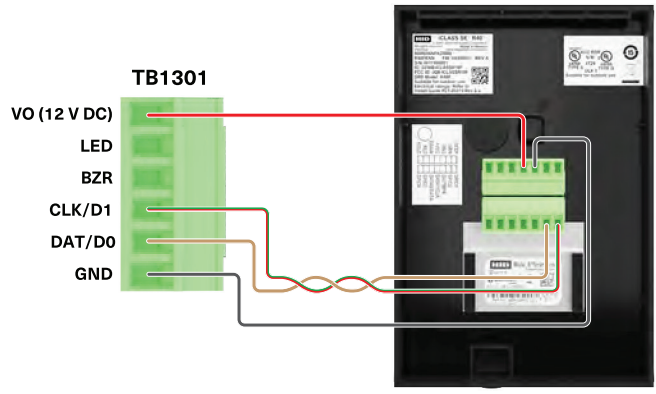

Reader port 1, typical reader 2
(Wiegand or Clock/Data installation)

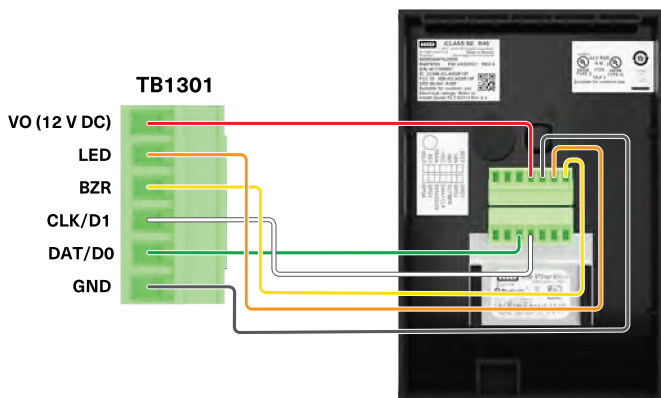

Reader port 2, typical reader 2
(Wiegand or Clock/Data installation)

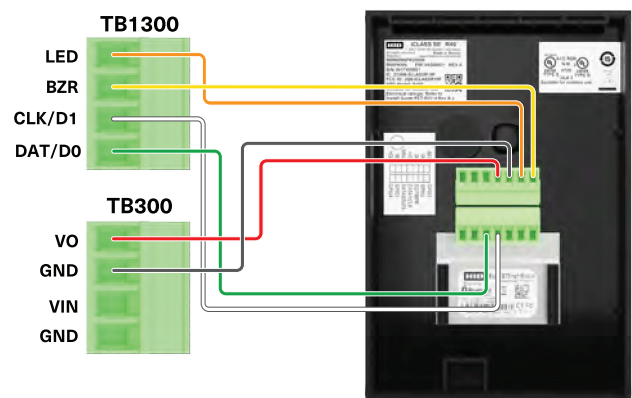

Reader port 1
Typical unsupervised F/2F reader

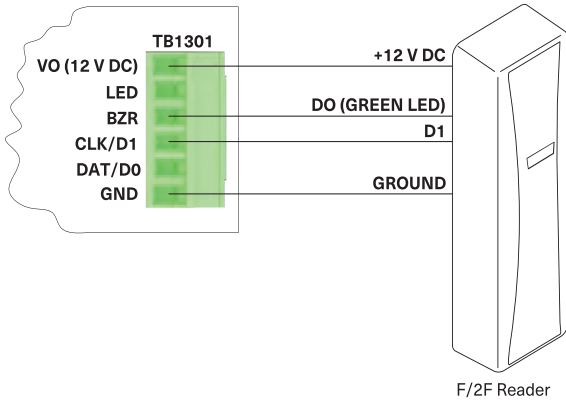

Reader port 2
Typical unsupervised F/2F reader

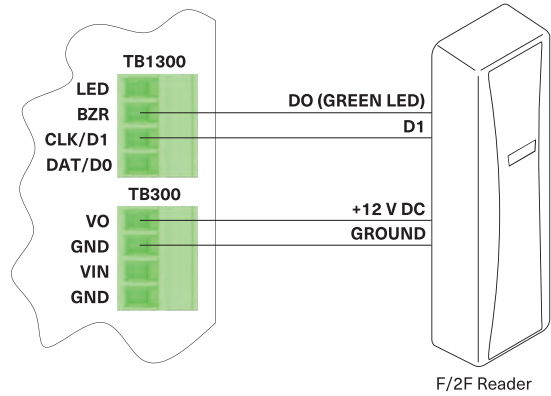

Reader port 1
Typical supervised F/2F reader

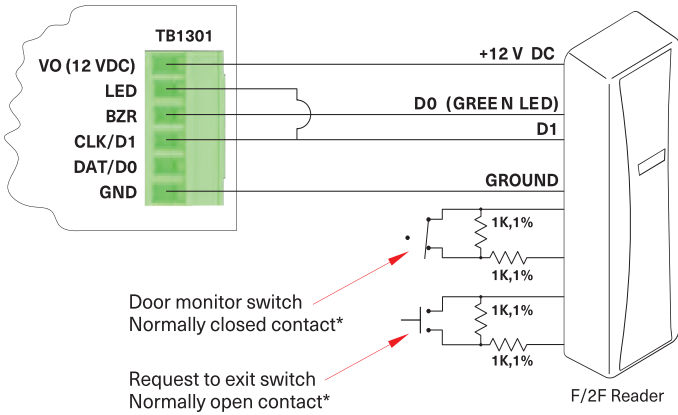

Reader port 2
Typical supervised F/2F reader

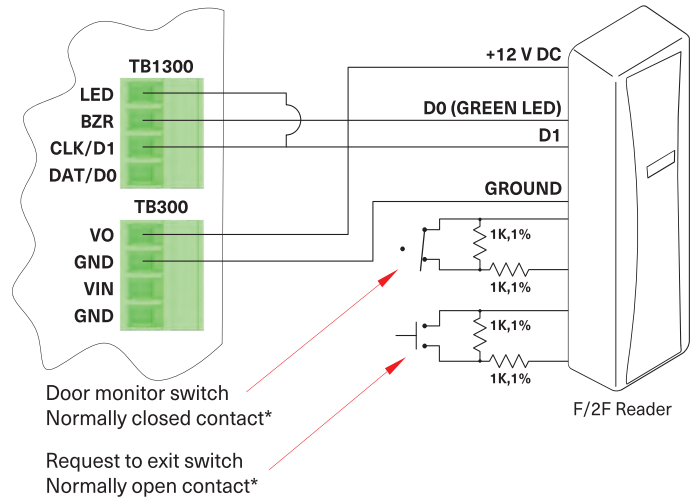

Jumper D1 and LED on supervised F/2F readers

*Inputs on supervised F/2F readers may be unsupervised or supervised (supervised shown).

Reader port 1 - remote serial I/O devices using MSP1 protocol (2-wire RS485)

Refer to the appropriate remote serial I/O device installation manual for address and baud rate settings. 120Ω end-of-line termination should only be added at each end of the RS-485 bus. If an MPI501 (ICM-MPI501) is at one end of the RS-485 bus, jumper J1201 can be installed to enable the termination resistor. Each remote serial I/O device must be configured with a unique communication address. A maximum of eight remote serial I/O devices can be connected to reader port 1. Cable shield: only ground one end.

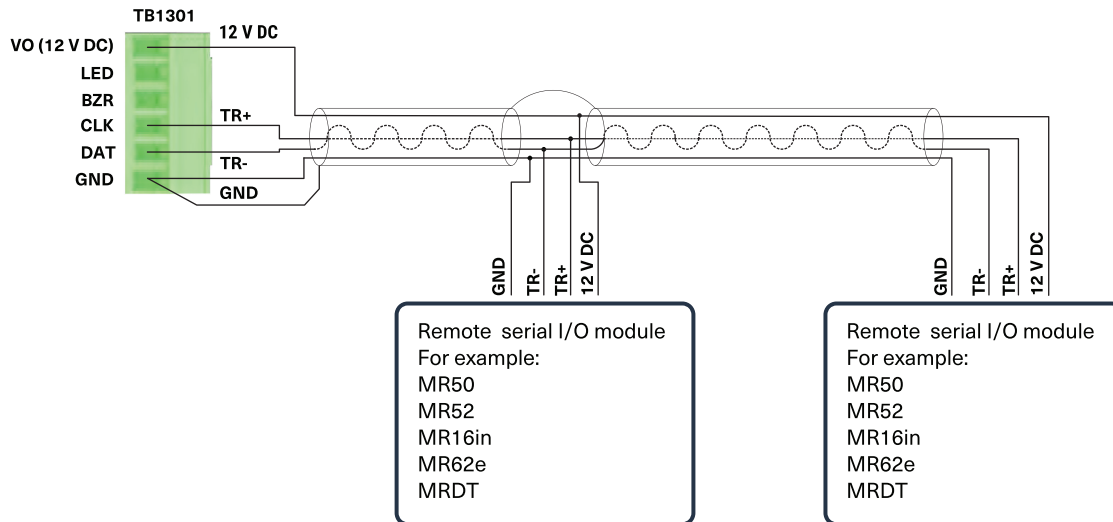

Reader port 1 - OSDP protocol devices (2-wire RS-485)

Refer to the appropriate OSDP device installation manual for address and baud rate settings. 120Ω end-of-line termination should only be added at each end of the RS-485 bus. If an MPI501 (ICM-MPI501) is at one end of the RS-485 bus, jumper J1201 can be installed to enable the termination resistor. Each OSDP device must be configured with a unique communication address. A maximum of two OSDP devices can be connected to reader port 1. Cable shield: only ground one end.

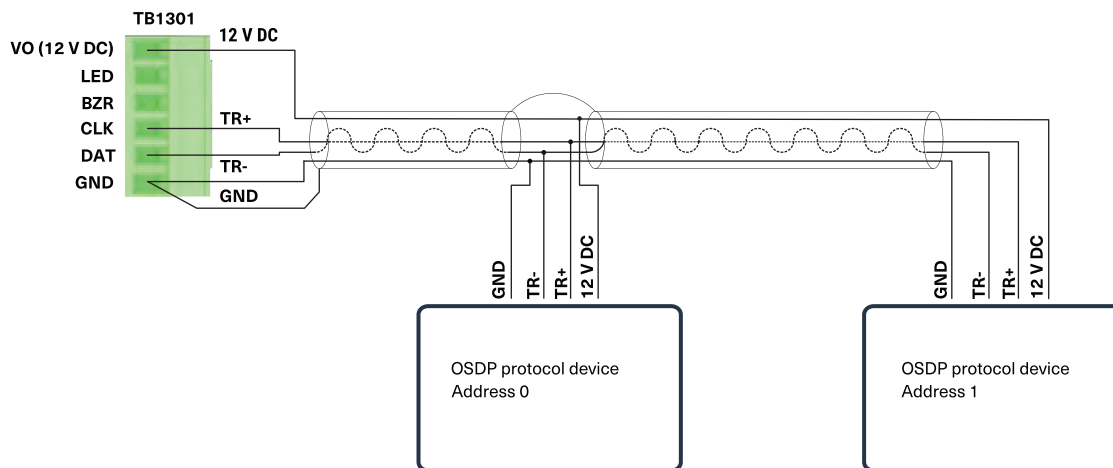

2.8 Communication wiring

The MPI501 (ICM-MPI501) controller communicates to the host via the on-board 10-BaseT/100Base-TX Ethernet interface.

2.9 Input circuit wiring

Typically, these inputs are used to monitor door position, request to exit, or alarm contacts. Input circuits can be configured as unsupervised or supervised. When unsupervised, reporting consists of only the open or closed states.

When configured as supervised, the input circuit will report not only open and closed, but also open circuit, shorted, grounded, and foreign voltage.

Note: Grounded and foreign voltage states are not a requirement of UL 294 and therefore not verified by UL.

A supervised input circuit requires two resistors are added to the circuit to facilitate proper reporting. The standard supervised circuit requires 1k Ω , 1% resistors and should be located as close to the sensor as possible. Custom end of line (EOL) resistances may be configured via the host software.

The input circuit wiring configurations shown are supported but may not be typical:

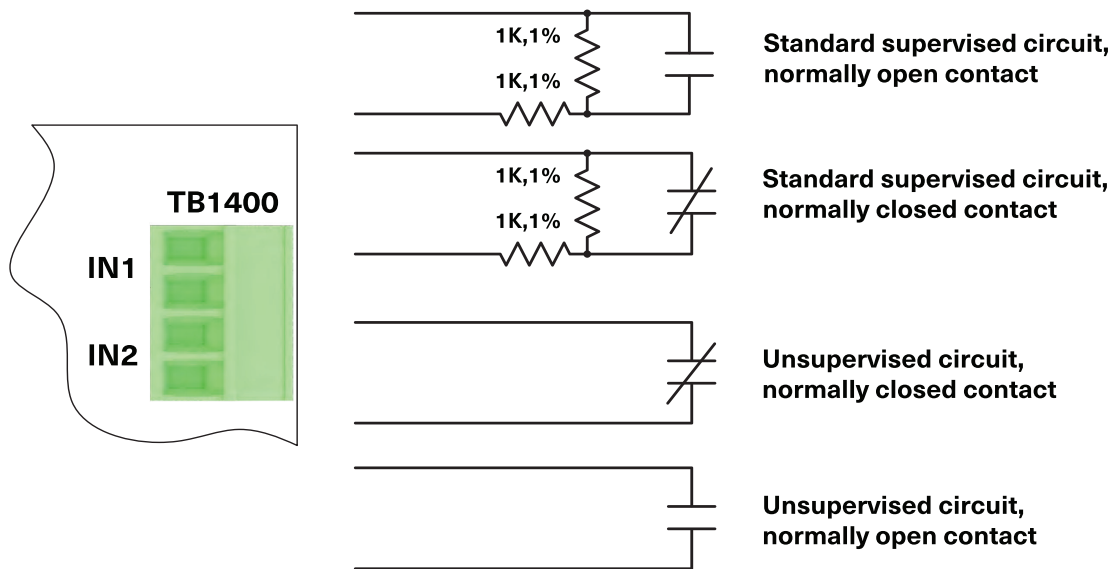

2.10 Relay circuit wiring

Two Form-C contact relays are provided for controlling door lock mechanisms or alarm signaling devices. The relay contacts are rated at 2 A @ 30 V DC, dry contact configuration. Each relay has a Common pole (C), a Normally Open pole (NO) and a Normally Closed pole (NC). When you are controlling the delivery of power to the door strike, the Normally Open and Common poles are used. When momentarily removing power to unlock the door, as with a mag lock, the Normally Closed and Common poles are used. Check with local building codes for proper egress door installation.

Door lock mechanisms can generate EMF feedback to the relay circuit that can cause damage and premature failure of the relay and affect the operation of the MPI501 (ICM-MPI501). It is recommended that either a diode or MOV (metal oxide varistor) is used to protect the relay. Wire should be of sufficient gauge to avoid voltage loss.

Caution: From the Auxiliary output, the MPI501 (ICM-MPI501) can provide 12 V DC power for external devices, provided that the maximum current is not exceeded. See Specifications for details. If a local power supply is used, it must be UL Listed Class 2 rated.

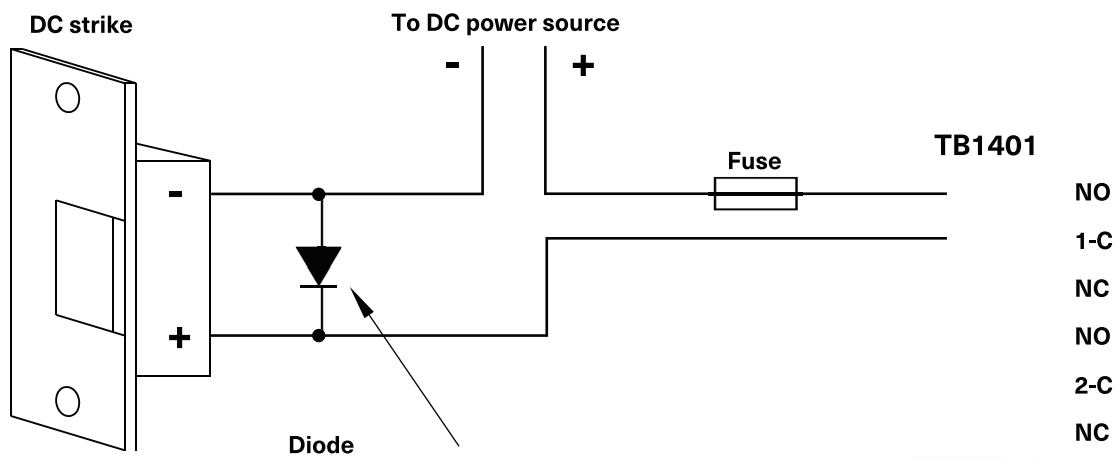

Diode selection

- Diode current rating: 1x strike current.
- Diode breakdown voltage: 4x strike voltage.
- For 12 V DC or 24 V DC strike, diode 1N4002 (100V/1A) typical.

2.11 Memory and real time clock back up

The real time clock is backed up by a super capacitor when power is interrupted. All other data is stored in non-volatile memory.

Note: Data is stored in flash memory to prevent loss of data in the case of power interruption.

2.12 Status LEDs

2.12.1 Power-up

NIC LED blinks and all other LEDs are off.

2.12.2 Initialization

The initialization process has several stages, each stage is represented by a different LED pattern in the following sequence:

- LED 1 is on for about 10 seconds.
- LED 2 is on for 25 seconds.
- LED 3 flashes slowly for 15 seconds.
- LED 3 flashes quickly for 1 second. LED 3 may continue flashing for an additional 60 seconds if the controller firmware is being updated.
- LED 1, LED 2, and LED 3 are off as the application starts.
- LED 4 is then on for 15 seconds indicating a successful initialization.

The amount of time the application takes to initialize depends on the size of the database, about one second without a card database. Each 10,000 cards will add about two seconds to the application initialization. When LEDs 1 through 4 flash at the same time, data is being read from or written to flash memory, do not cycle power when in this state. If the sequence stops or repeats, perform the bulk erase procedure, See **2.5 Bulk erase configuration memory**. If clearing the memory does not correct the initialization problem, contact Tech Support (support@idcubesystems.com).

2.12.3 Running

After initialization is complete, the LEDs have the following meanings:

LED	Description
1	Off-Line / On-Line: Off-Line = 20% ON, On-Line = 80% ON
2	Host communication activity
3	Readers (combined): Clock/Data or D1/D0 Mode = Flashes when data is received, either Input. RS-485 Mode = Flashes when transmitting data F/2F Mode = Flashes when data/acknowledgment is received
4	Input IN1 Status: OFF = Inactive, ON = Active, Flash = Fault ¹
5	Input IN2 Status: OFF = Inactive, ON = Active, Flash = Fault ¹
6	Cabinet tamper
7	Reserved for future use
K1	Relay K1: ON = Energized
K2	Relay K2: ON = Energized
YEL	Ethernet Speed: OFF = 10 Mb/S, ON = 100 Mb/S
GRN	OFF = No link, ON = Good link, Flashing = Ethernet activity

1. If this input is defined, every three seconds the LED is pulsed to its opposite state for 0.1 seconds, otherwise, the LED is off.

2.13 IT Security

Ensure that the MP1501 is installed securely. Create user accounts to the web configuration page using secure passwords.

Ensure all DIP switches are to be in the OFF position for the normal operating mode.

The MP1501 is shipped from the factory with a default login account, which is enabled when DIP 1 is moved from OFF to ON (See DIP switches). The default login user name (admin) and password (password) will be available for five minutes once the DIP switch is toggled. It is therefore important that at least one user account is defined, and the DIP switches are set to OFF before the MP1501 (ICM-MP1501) is commissioned.

Configuring the MP1501 (ICM-MP1501) with an IP address that is accessible from the public is not recommended.

The following options are available for enhanced network security:

- Disable SNMP.
- Zeroconf discovery.
- The web configuration module.
- Enable data encryption over the host communication port.

3. Specifications

3.1 MP1501 (ICM-MP1501) controller specifications

The interface is for use in low voltage, Class 2 circuits only.

The installation of this device must comply with all local fire and electrical codes. Units are to be installed in accordance to NFPA 70. The unit is to be powered with a UL listed UL 294 approved power supply with a class 2 power limited output UL verified at 12 V DC.

Primary power	PoE (12.95 W), compliant to IEEE 802.3af or PoE+ (25 W), compliant to IEEE 802.3at or 12 V DC $\pm 10\%$, 1.8 A maximum
Power output	PoE: Powered via PoE max = 625 mA including reader and auxiliary power output ¹
Power output	PoE+ or external 12 V DC: 12 V DC @ 1.25 A including reader and auxiliary power output ¹
Micro USB port	5 V DC maximum (deduct 270 mA from reader and auxiliary power output) Not Evaluated by UL

1. Excluding micro USB port



Caution: PoE power is to be supplied by a Listed ITE or Access Control System Unit (ALVY), power limited, PoE+ injector or PoE+ Ethernet switch providing 42.5 – 57 V DC, 25.5 W for maximum output.

RTC Back up	Super capacitor
microSD card	Format: microSD or microSDHC; 2GB to 8GB.
Host communication	Ethernet: 10-BaseT/100Base-TX and Micro-USB port (2.0) with optional adapter: pluggable model USB2-OTGE100
Inputs	Two unsupervised/supervised, programmable end of line resistors, 1k/1k Ω , 1%, ¼ watt standard
	One unsupervised input dedicated for cabinet tamper
Outputs	Two relays: Form-C contacts: 2 A @ 30 V DC, resistive
READER INTERFACE	
Power	12 V DC $\pm 10\%$: PoE, PoE+ or local power supply, 600 mA maximum per port
Data inputs	Reader port 1: TTL compatible, F/2F or 2-wire RS-485 Reader port 2: TTL compatible or F/2F
LED output	TTL compatible, high > 3 V, low < 0.5 V, 5 mA source/sink maximum
Buzzer output	Open collector, 12 V DC open circuit maximum, 40 mA sink maximum

CABLE REQUIREMENTS	
Power	1 twisted pair, 18 AWG (when using local 12 V DC power supply)
Ethernet	CAT-5, minimum
Reader data (TTL)	6-conductor, 18 AWG, 500 feet (152 m) maximum
Reader data (F/2F)	4-conductor, 18 AWG, 500 feet (152 m) maximum
Reader data (RS-485)	1 twisted pair, shielded. 24 AWG, 120Ω impedance, 2000 feet (610 m) maximum
Alarm input	1 twisted pair per input, 30Ω maximum
Outputs	As required for the load
ENVIRONMENTAL	
Storage temperature	-55 to +85°C
Operating temperature	0 to +70°C
Humidity	5 to 95% RHNC
MECHANICAL	
Dimensions without bracket	5.5 inches (140 mm) W x 2.75 inches (70 mm) L x 0.96 inches (24 mm) H
Dimensions with bracket	5.5 inches (140 mm) W x 3.63 inches (92 mm) L x 1.33 inches (34 mm) H
Weight without bracket	3.6 oz. (103 g)
Weight with bracket	4.43 oz. (125.5 g)

UL294 Performance Levels ULC 60839-11-1 Indoor use

Feature	Level
Standby Power	I
Endurance	IV
Line Security	I
Destructive Attack	I

These specifications are subject to change without notice.

The models described in the manual are recognized boards intended to be used with ULC 60839-11-1 enclosures, power supply readers, controllers, I/O boards, and an off premise monitoring station to form a grade 2 or higher system. Units may be used in grade 4 system installations provided the full system with this board integrated is verified in the end use application. The boards mentioned have only been evaluated for their specific function for grade 2 requirements. For ULC 60839-11-1 an enclosure with a tamper is required and a reader and power supply is to be verified in the end product, as well as the operations need to be documented in the installation instructions.

4. Additional mounting information

4.1 Optional items

Sources for the optional items shown below:

- **3-gang stainless steel blank cover. Available from:**
 - **Leviton: part number 84033-40**
 - **Graybar: part number 88158404**
- **Magnetic switch set: G.R.I. part number: 505**

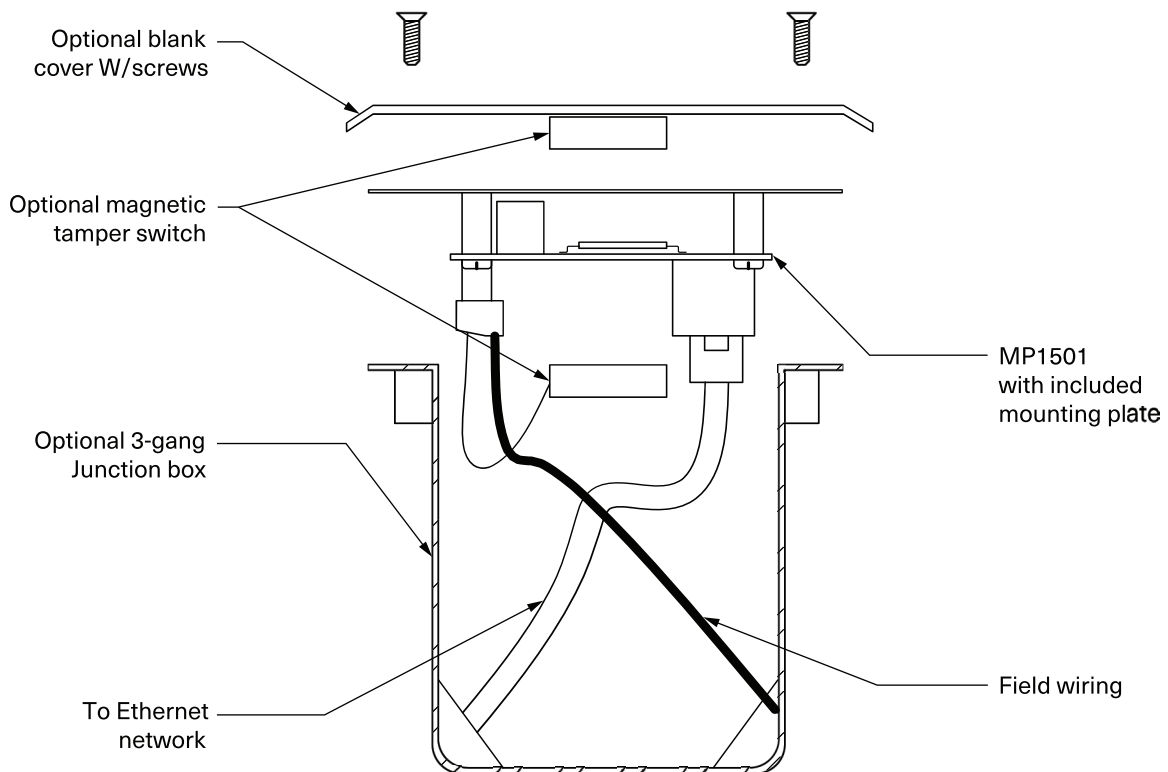

4.2 Mounting plate dimensions

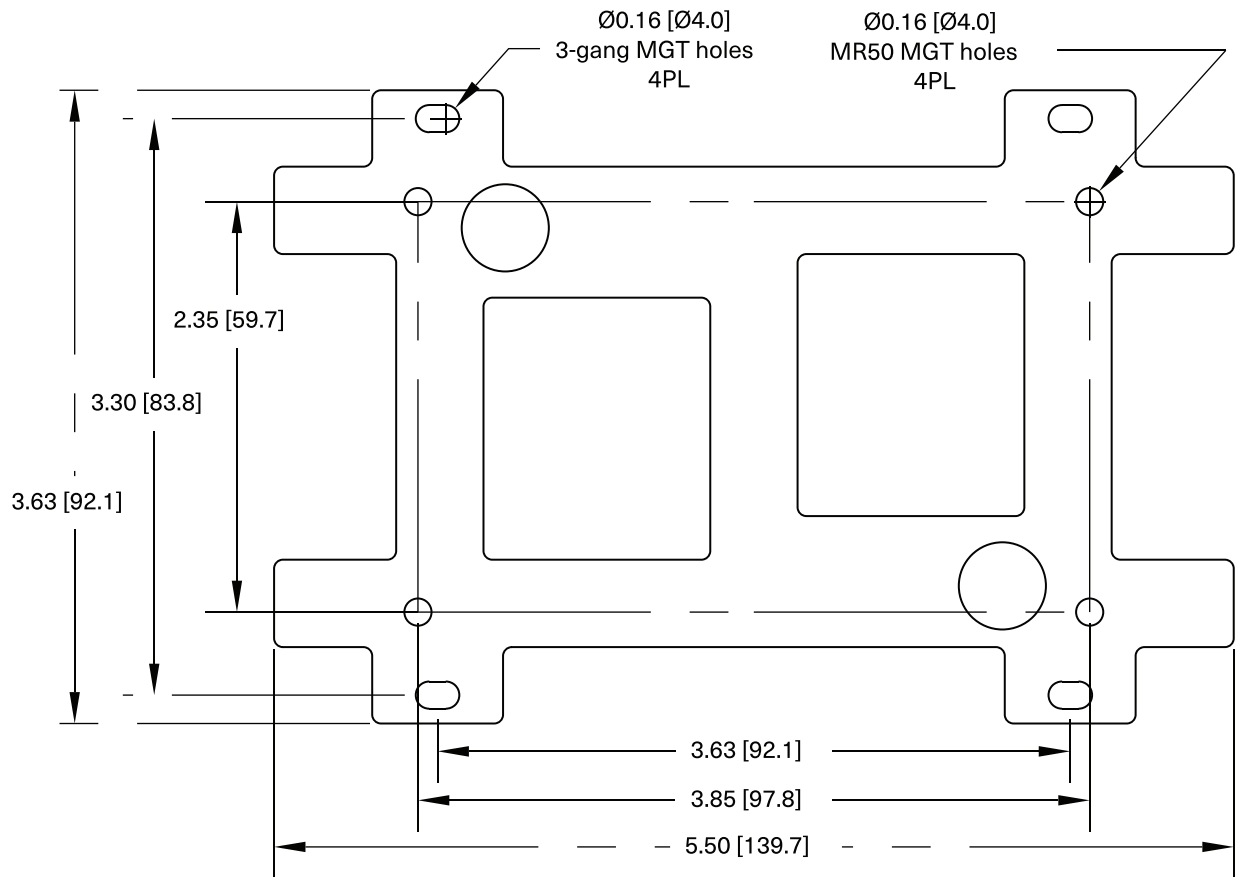

USA

IDCUBE Corporation
20, Corporate Place South, 691 S Milpitas Blvd
2nd Floor, Piscataway, Ste 217 Milpitas
New Jersey – 08854 USA CA 95035 USA

Toll-free number: +1 (833) 703-1765

UAE

IDCUBE FZE
Techno Hub 1 – Office
F 144 Dubai Silicon
Oasis Dubai, UAE

+971 4 388 7900

INDIA

IDCUBE Identification Systems
(P) Ltd.
B-19, Sector-2, Noida-201301
Uttar Pradesh, INDIA

+91 76761 10110

This document includes proprietary material owned by IDCUBE and its partners. Reproduction, sharing, or use beyond its intended purpose is not permitted unless formally authorised, and any approved copies must carry this notice.

© 2026 IDCUBE. All rights reserved.

For technical support, reach out us at: support@idcubesystems.com

Scan to explore
our website

